

SUPERPLAN

- exclusive, elegant design
- with a depth of 2,5 cm, extremely flat and ideally suited for floor level installation
- made of Kaldewei steel enamel 3,5 mm
- model 399 with full anti-slip conforms to DIN-barrier-free 18025-2



Similar illustration

Illustration shows Model 405

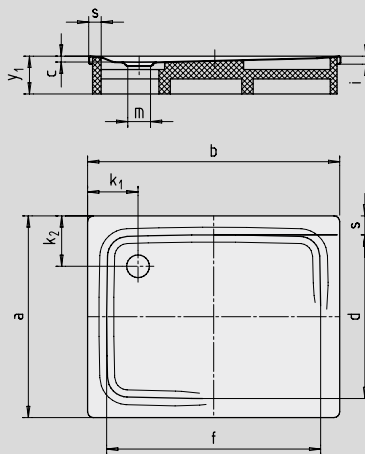
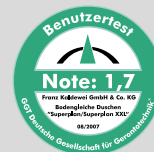
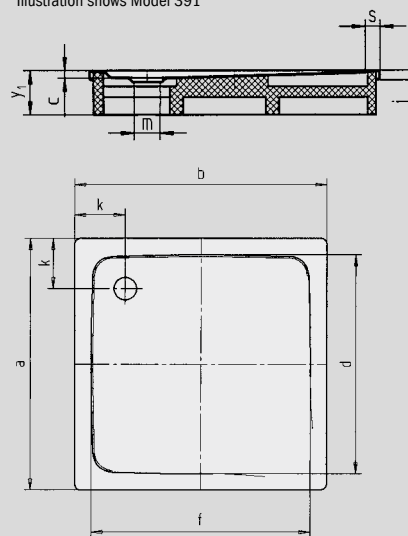

Illustration shows Model 391



Model No.		391	405	401	403	389	406	407	399
External length	a	1000	900	700	750	800	900	1000	1200 mm
External width	b	1000	1100	1200	1200	1200	1200	1200	1200 mm
Depth	c	25	25	25	25	25	25	25	25 mm
Internal length	d	870	790	590	640	700	790	890	1070 mm
Internal width	f	870	990	1090	1090	1100	1090	1090	1070 mm
Height of rim	i	32	32	32	32	32	32	32	32 mm
Distance tray edge to centre of drain hole	k ₁ ; k ₂	200	200	200	200; 225	200	200	200	200 mm
Diameter of drain hole	m	90	90	90	90	90	90	90	90 mm
Width of rim	s	65	55	55	55	50	55	55	65 mm
Height with support	y ₁	120	120	120	120	120	120	120	120 mm
Weight of the enamelled shower tray in kg		27	26	23	24	25	29	31	37
Anti-slip		∅ 588	∅ 588	∅ 435	∅ 435	∅ 588	∅ 588	∅ 588	∅ 588 mm
Full anti-slip		733 x 781	649 x 853	461 x 997	524 x 997	586 x 996	649 x 997	773 x 997	1060 x 1105 mm

Mod. 399

The TÜV Rheinland confirms the following properties of KALDEWEI's anti-slip and full anti-slip finish:

- Assessment group **B** for wet barefoot areas (**DIN 51097**)
- Assessment group **R 10** for slip-resistant properties in work rooms and areas with an increased risk of slipping (**DIN 51130**)

All SUPERPLAN models are available with **full anti-slip** finish.

Mod. 399 with full anti-slip finish meets the requirements of **DIN-barrier-free 18025-2**.