



# SQ50 TYPE TECHNICAL DATA SHEET



## ● PRODUCT DESCRIPTION

Easy fit Thermostatic Cartridge for accurate control of water temperature. Built in anti scald function. Reversible Patented Technology. Manufactured from a high grade engineered polymer which is extremely resistant to calcium build up. Suitable for use on LP and HP applications. Manufactured from WRAS approved materials. When this cartridge is used in conjunction with our designated shower body, TMV3 compliance will be achieved.

## ● PRODUCT APPLICATION EXAMPLES

Sequential shower valves which have single control of water flow and temperature.

## ● TECHNICAL DATA

Max Working Pressure: 10 bar Static  
 Min Working Pressure: 0.1 bar Dynamic  
 Hot Supply Temp: 55°C-65°C  
 Cold Supply Temperature: ≤25°C  
 Max Inlet ratio: 5:1

## ● PATENTS

GB-2399159, EP-1463982, US-6994266, CN-1628275

## ● TYPICAL APPLICATION EXAMPLES:



## ● DIMENSIONED DRAWING & HOUSING REQUIREMENT:

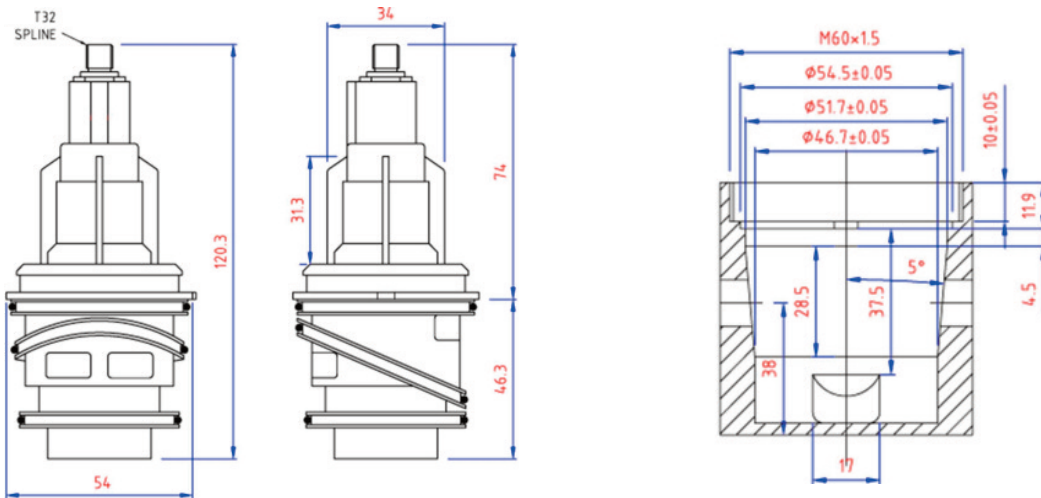

POWERED BY  
**VALQUEST**

● FLOW RATES

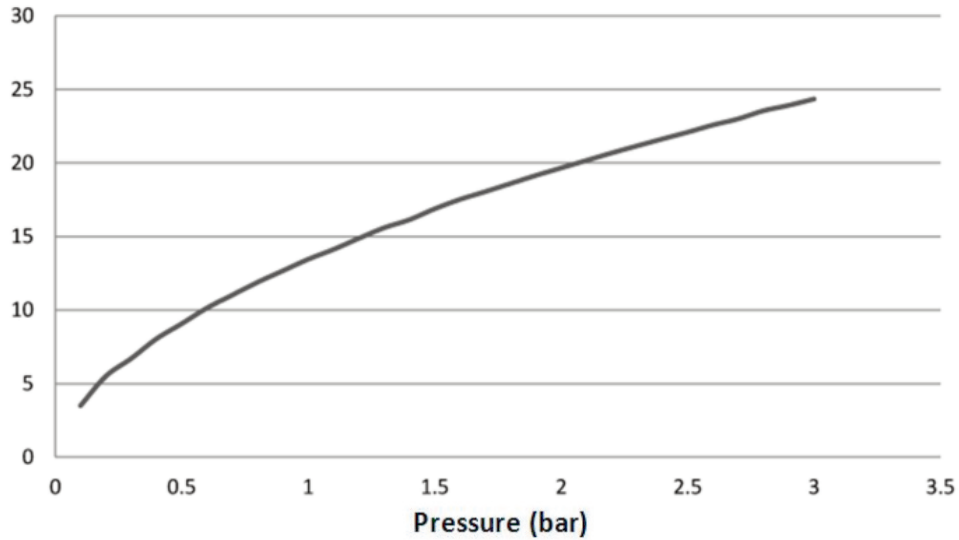

An SQ50 Cartridge was placed in a standard body in order to record the above Pressure vs. Flow graph.

● THERMOSTATIC PROPERTIES

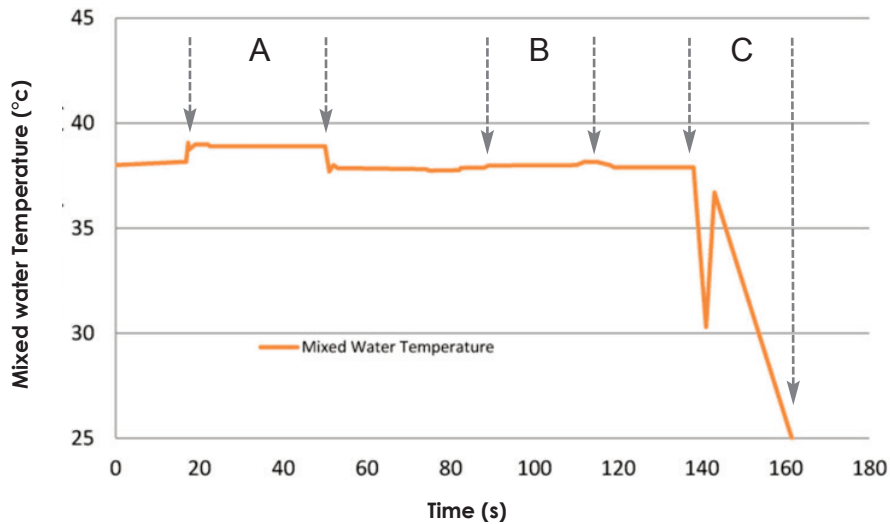

Note: This test was carried out using a standard body. The initial Hot and Cold inlet pressures were 3 bar.

- A The cold water inlet pressure was dropped by 0.5 bar during this time.
- B After restoring the cold water pressure to 3 Bar the flow was halved by using an external valve.
- C After restoring the flow the cold water inlet water was shut off.



INVESTORS IN PEOPLE



**ULTRA**  
**FINISHING**



Ultra Finishing Ltd, Widow Hill Road, Heasandford Industrial Estate, Burnley, Lancashire, BB10 2BQ  
Tel: +44 (0)1282 436934, Fax: +44 (0)1282 418026, Website: [www.ultra-group.co.uk](http://www.ultra-group.co.uk)