

34 193

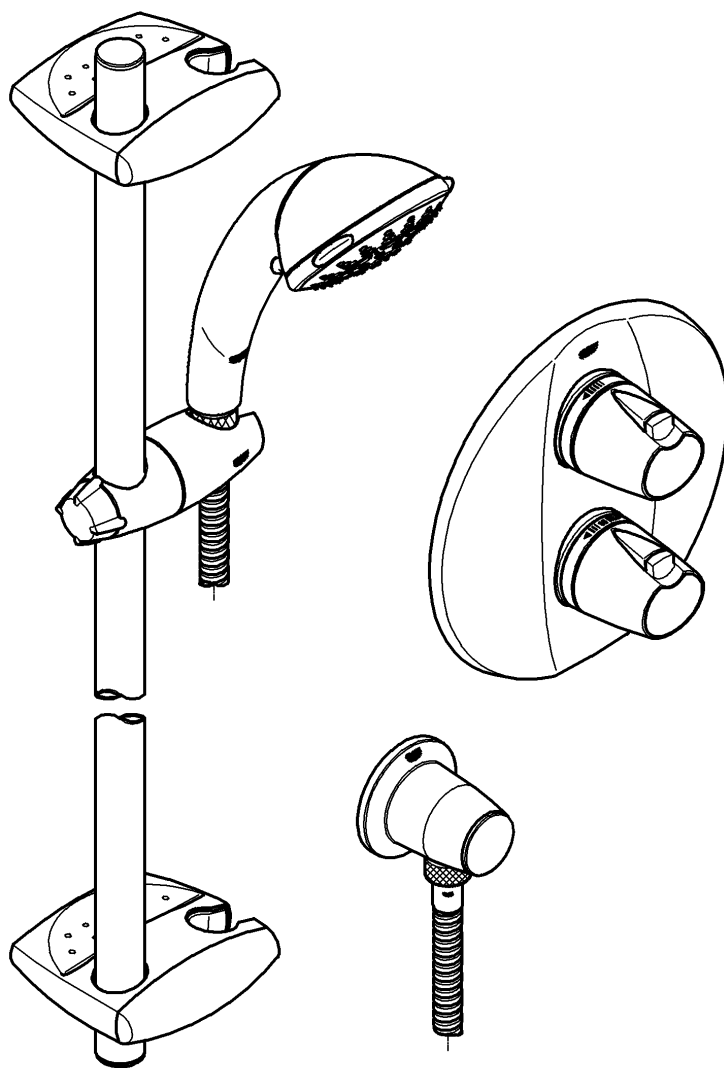

Grohtherm 3000

Grohtherm 3000

GB1

94.690.131/ÄM 205984/08.06

GROHE
ENJOY WATER®

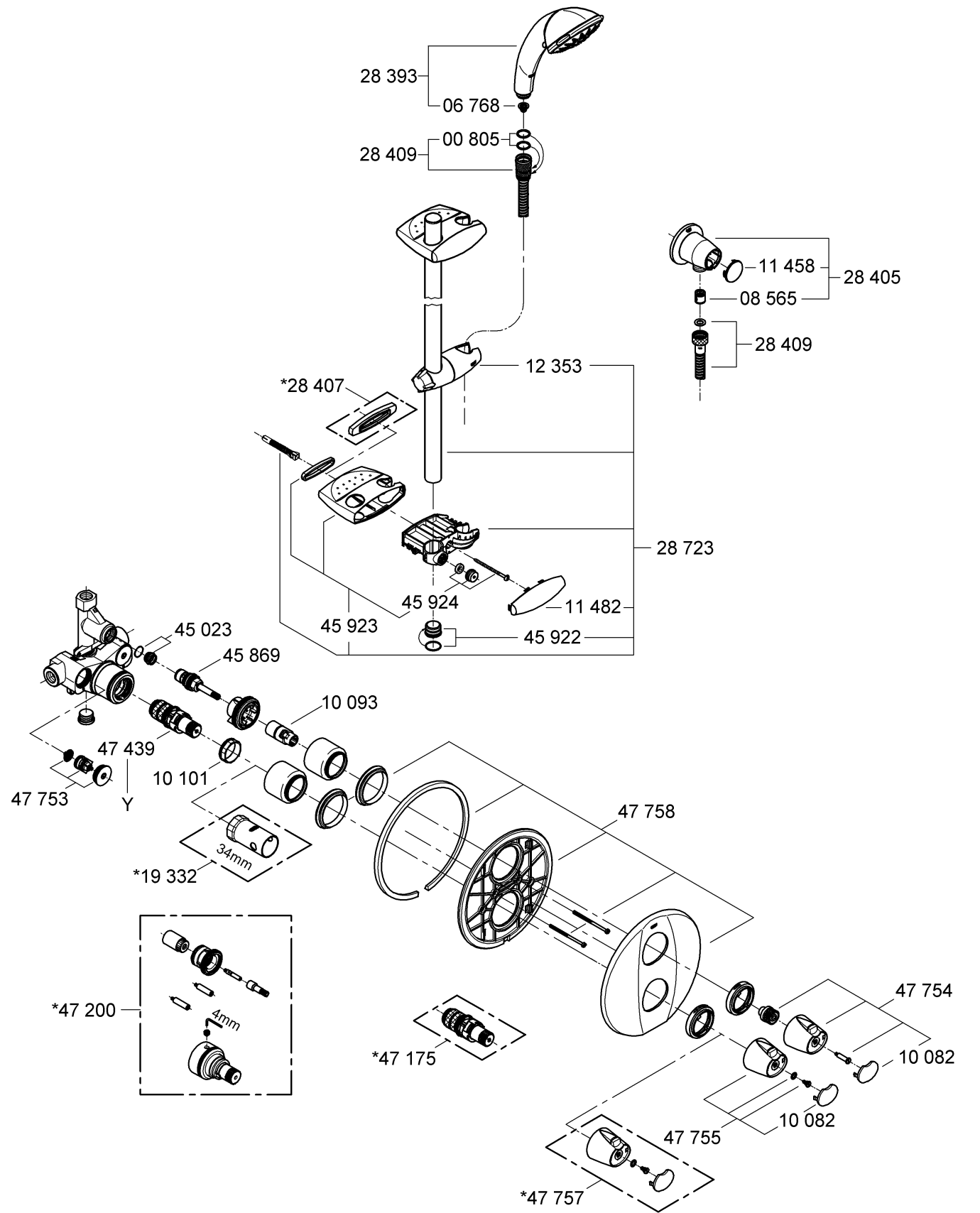
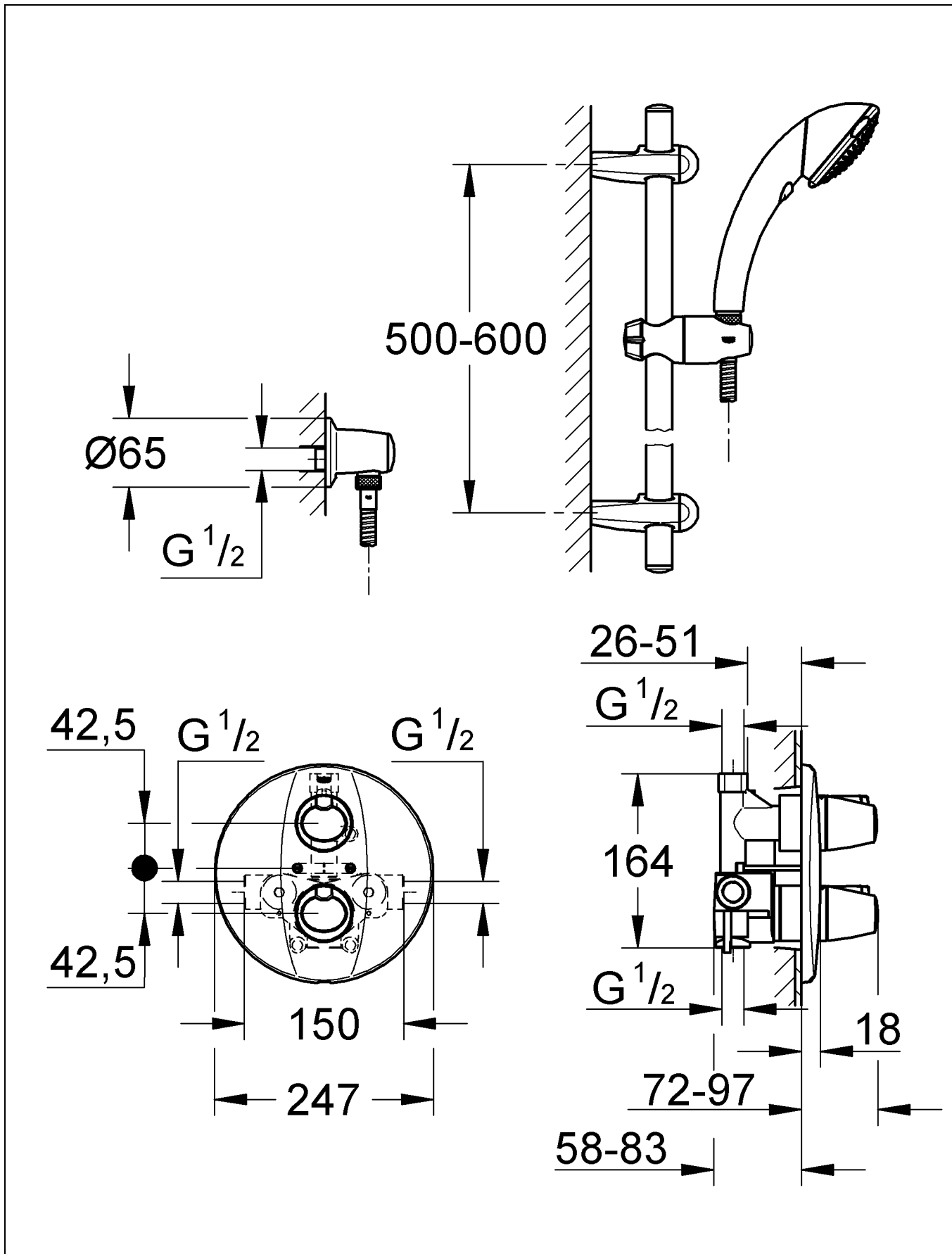

Please pass these instructions on to the end user of the fitting.

1	a	b	c
	1/2"		29 800
	ø 15mm		29 801
	3/4"		29 802
	ø 18mm		29 803
	ø 22mm		29 804

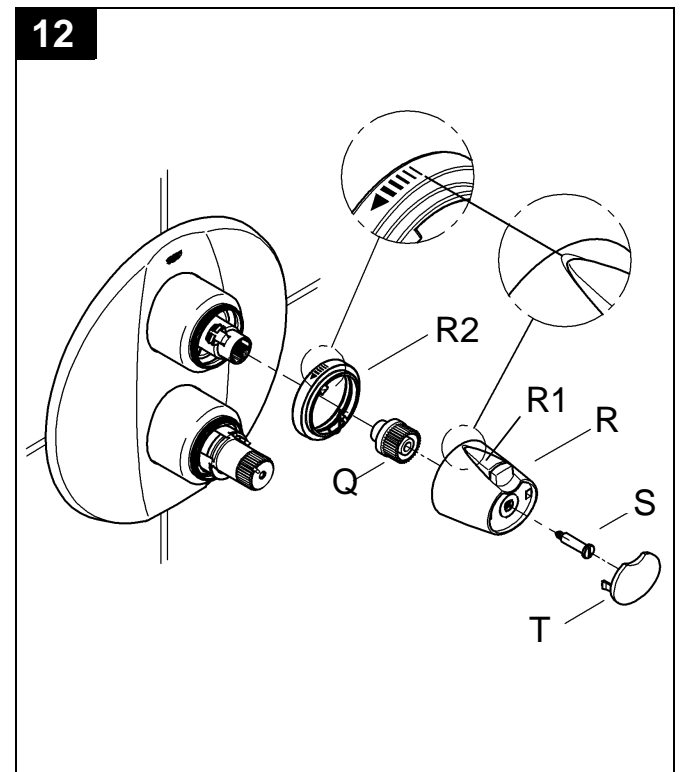
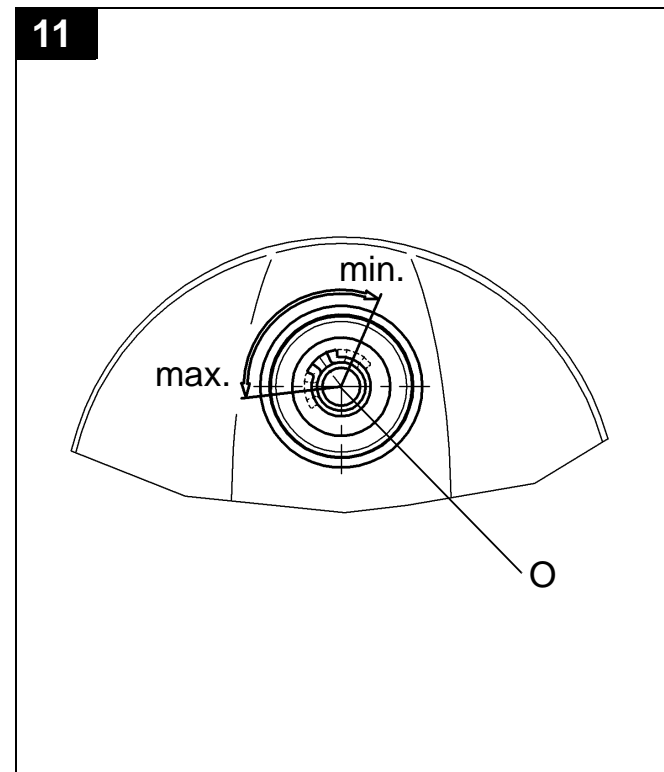
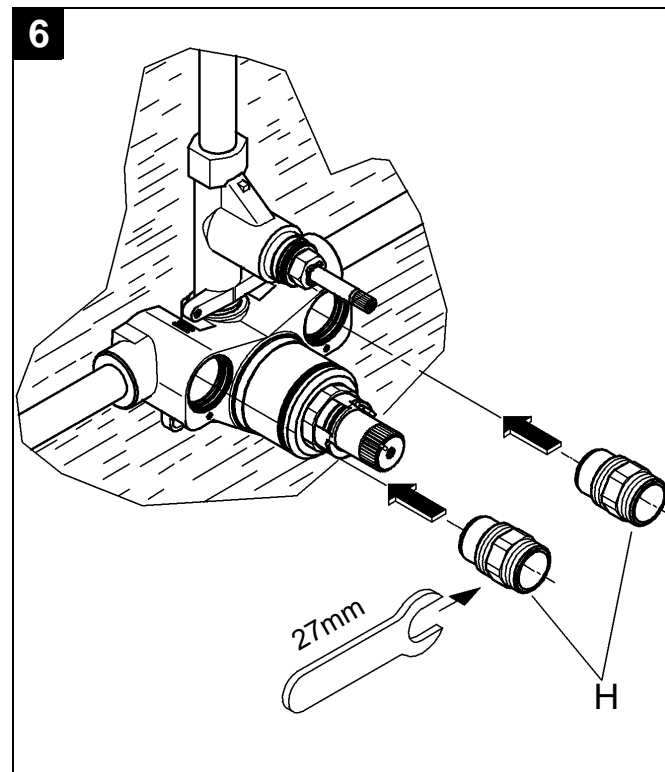
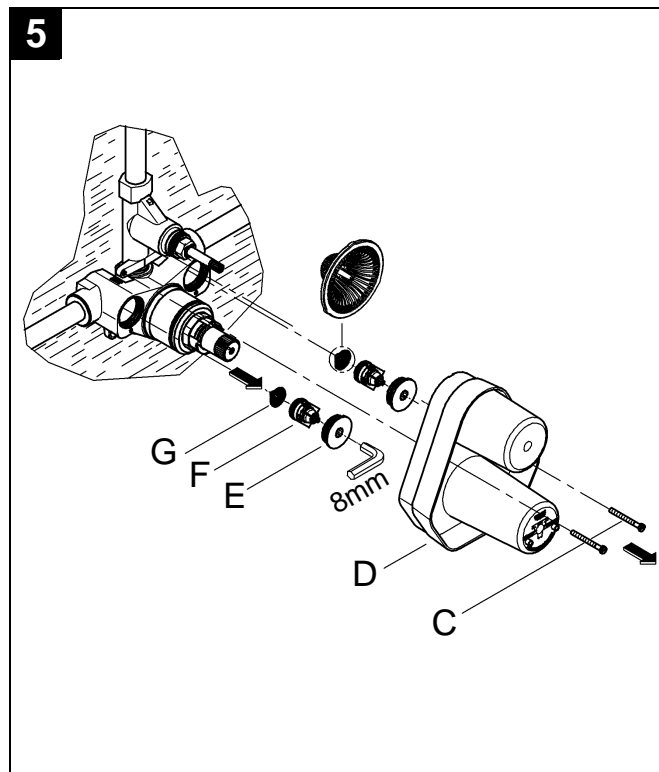
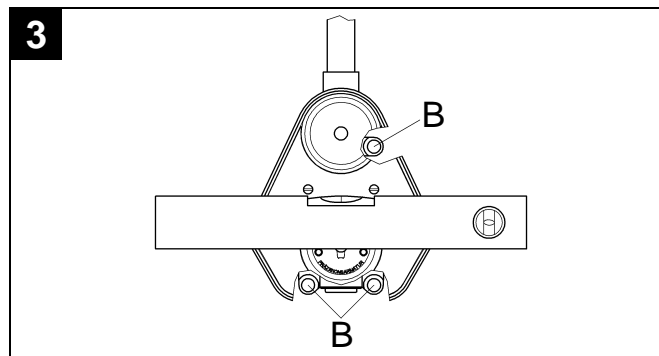
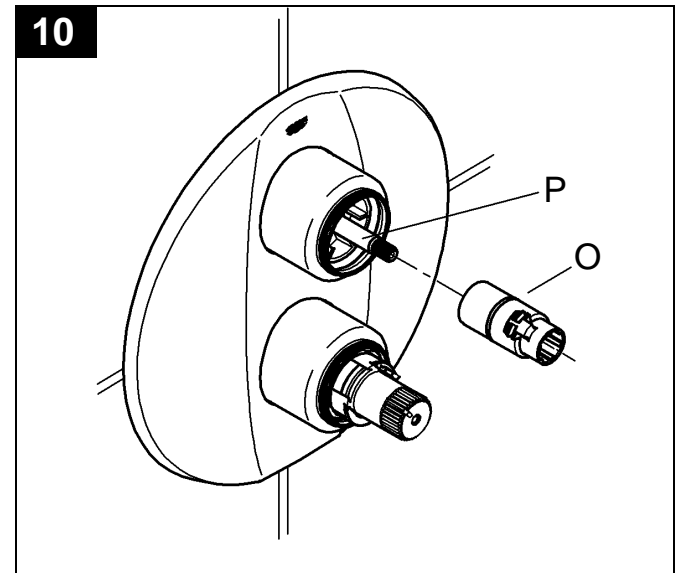
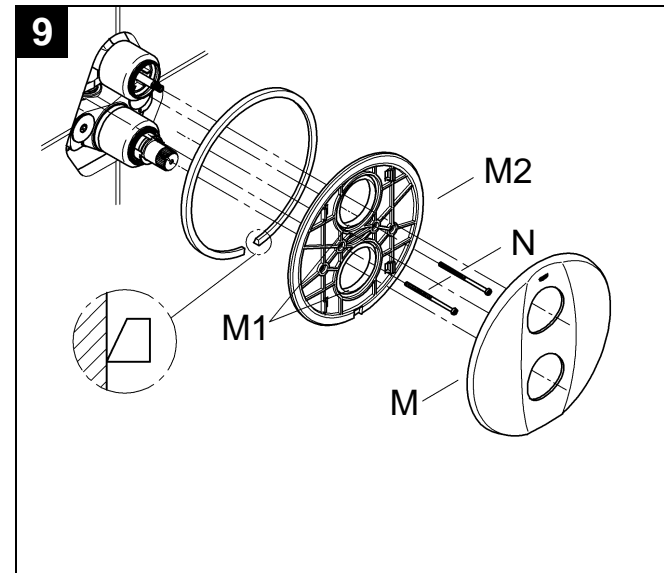
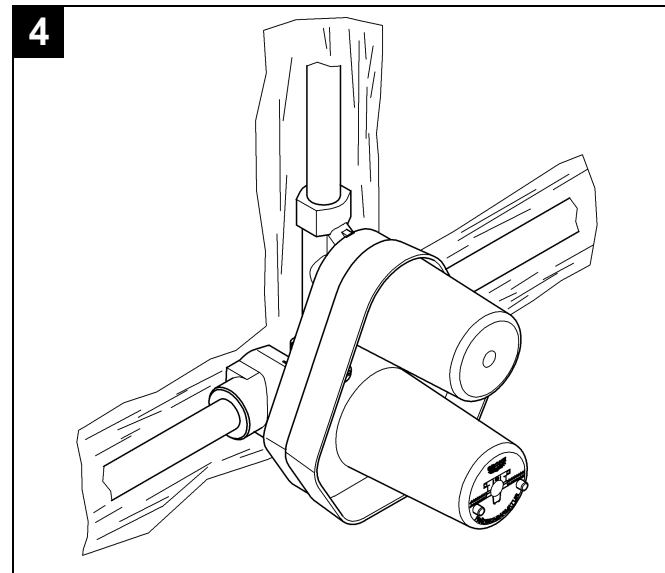
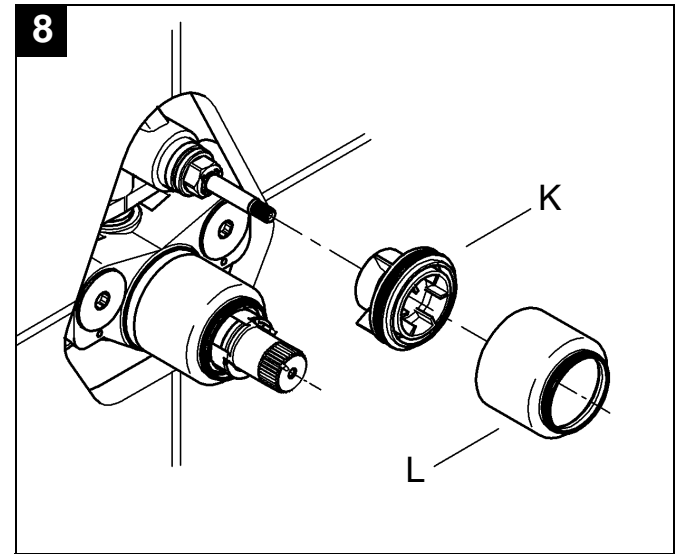
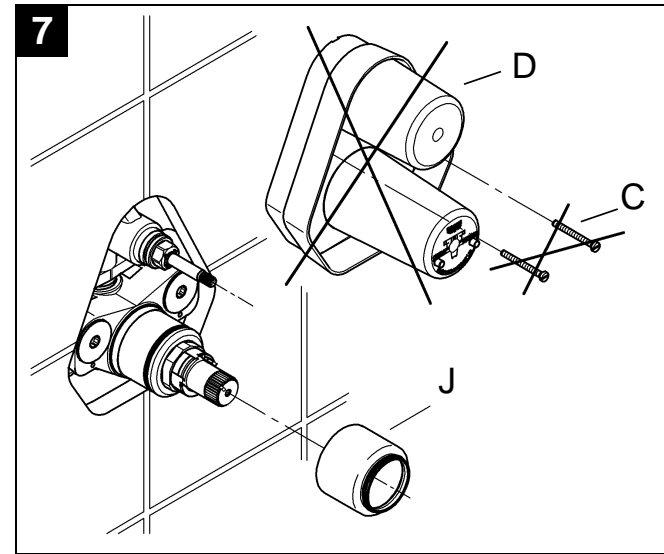
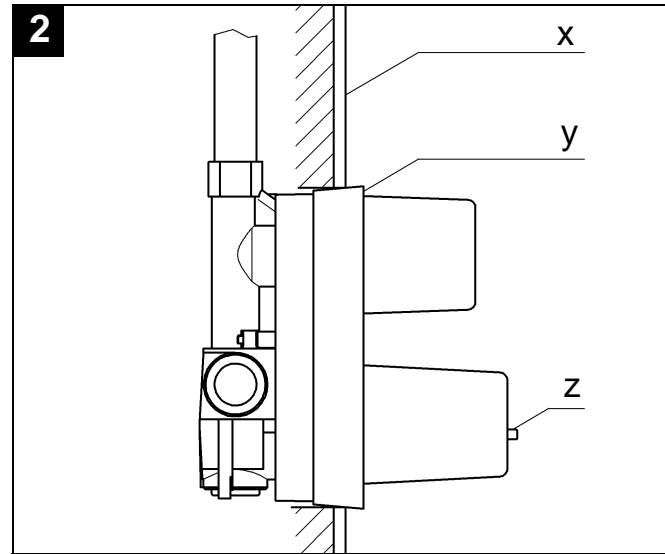



Application

Thermostat mixers are designed for hot water supplies from pressurised storage heaters and offer the highest temperature accuracy when used in this way. Given sufficient output (min. 18 kW or 250 kcal per min), electric or gas-fired instantaneous heaters are also suitable.

Thermostat mixers cannot be used in conjunction with low-pressure storage heaters (displacement heaters).

All thermostat mixers are adjusted at the factory at a flow pressure of 3 bar on both sides.

The built-in thermostat only shuts off the upper outlet. An additional stop valve must be fitted if the lower outlet is used.

For an order number index to the various installation components for the concealed mixer, see fold out page II fig. [1].

a = Size of union
b = Part
c = Part No.

Technical Data

Minimum flow pressure without downstream resistances	0.5 bar
Minimum flow pressure with downstream resistances	1 bar
Max. operating pressure	10 bar
Recommended flow pressure	1 - 5 bar
Test pressure	16 bar
Flow rate at 3 bar flow pressure	approx. 24 l/min
Max. water temperature at hot water inlet	80 °C
Recommended max. flow temperature (for energy saving)	60 °C
Safety stop	38 °C
Hot water temperature at supply connection min. 2 °C higher than mixed water temperature.	
Hot water connection - W - (-H-)	left
Cold water connection - K - (-C-)	right
Minimum flow rate	5 l/min

At a flow pressure over 5 bar it is recommended that a pressure reducing valve be fitted in the supply line.

New installations

- Prepare wall ready for mixer. Drill holes for thermostat mixer and chase-out grooves for pipelines.
- Observe the installation depth in accordance with the instructions given on the mounting template, see also fold out page II fig. [2].

x = Face of tiles
y = Front face of mounting template
z = Resting point for spirit level

- Align the mixer horizontally, vertically and parallel to the wall, see fig. [3] (place a spirit level on the cams or face of the mounting template).

- Install concealed thermostat mixer module in wall and connect pipelines, see fig. [4].

The housing is provided with pre-drilled holes (B) to facilitate mounting the fitting to the wall, see fig. [3].

- **Do not solder the connections between the pipelines and housing**, otherwise the built-in non-return valves may be damaged.

- Seal the open outlet with screw plug.

Note!

- **The hot water supply must be connected on the left** (marked W (H) on housing) **and the cold water supply on the right** (marked K (C) on housing), **as viewed from the operating position.**

Open cold and hot water supplies.

Test the pipelines and concealed thermostat module connections for leaks.

Flush pipelines thoroughly.

1. Remove screws (C) and mounting template (D), see fig. [5].
2. Close the hot and cold water supplies.
3. Remove screw plug (E).
4. Remove non-return valve (F) and filter (G).
5. Install flushing plugs (H) in non-return valve seat recesses, see fig. [6].
6. Open the hot and cold water supplies and flush pipes thoroughly.
7. Close the hot and cold water supplies and remove flushing plugs (H).
8. Install filter (G) and non-return valve (F), see fig. [5].
9. Install screw plug (E).
10. Reinstall mounting template (D).

Plaster and tile the wall, excluding the area occupied by the mounting template. Seal any apertures in the wall so that they are watertight to spray water.

- Tiles laid in mortar should be pointed so that the joint is tapered towards the outside.

- Seal prefabricated walls with a permanently plastic compound.

Do **not** remove the fitting template before final installation.

Final installation

1. Remove screws (C) and mounting template (D), see fig. [7].
2. Install sleeve (J).
3. Install holder (K) and fit sleeve (L), see fig. [8].
4. Grease the seals (M1) for the escutcheon mounting bracket (M2) with the special grease supplied and install escutcheon mounting bracket (M2) with screws (N), see fig. [9].
5. Fit the escutcheon (M).

If the thermostat has been installed at too great a depth, this can be adjusted by 27.5mm with an extension set (see fold-out page I, ref. No. 47 200).

Open cold and hot water supplies.

Installation of the flow control knob and adjustment of the economy stop, see figs. [10] to [12].

- The flow rate is limited by the economy stop (O) supplied, see fig. [10].

To install the flow control knob, proceed as follows:

1. Close the ceramic headpart (P) by turning clockwise.
2. Install the economy stop (O) in the desired position.

For possible settings, see fig. [11].

3. Fit scale ring (R2), see fig. [12].
4. Fit splined adapter (Q).
5. Install flow control knob (R) so that the button (R1) is at top.
6. Reinstall screw (S).
7. Fit cap (T).

If a higher rate is desired, the stop can be overridden by depressing the button (R1).

Reversed connection (hot on right - cold on left). Replace thermostatic compact cartridge (Y), see Replacement Parts, fold-out page I, Prod. no. 47 175 (1/2").

Adjustment

Installation of the thermostat knob and temperature adjustment, see fold-out page III figs. [13] and [14].

- Before the mixer is put into service if the mixed water temperature measured at the point of discharge varies from the specified temperature set on the thermostat.
 - After any maintenance operation on the thermoelement.
1. Open the shut-off valve and check the temperature of the water with a thermometer, see fig. [13].
 2. Turn the adjusting nut (U) clockwise or anticlockwise until the water temperature reaches 38 °C.
 3. Fit scale ring (V2), see fig. [14].
 4. Install temperature control handle (V) so that the button (V1) is at top.
 5. Reinstall screw (W).
 6. Fit cap (X).

Temperature limitation

The safety stop limits the temperature range to 38 °C. If a higher temperature is desired, the 38 °C limit can be overridden by depressing the button (V1), see fig. [14].

Temperature limit stop

If the temperature limit stop should be 43 °C, use handel ref. No. 47 757 (see fold-out page I).

Prevention of frost damage

When the domestic water system is drained, thermostat mixers must be drained separately, since non-return valves are installed in the hot and cold water connections. The complete thermostat assemblies and non-return valves must be unscrewed and removed.

Maintenance

Inspect and clean all parts, replace if necessary and grease with special valve grease.

Shut off cold and hot water supplies.

I. Thermostatic compact cartridge (Y), see fold-out page III, fig. [15] to [17].

- Loosen screw ring (Z) using a 34mm tool.
- If necessary, lever out thermostatic compact cartridge (Y) via recess (Y1).
- Remove screw ring (Z).

Install in reverse order.

Observe the correct installation position of the thermostatic compact cartridge (Y), see detail (Y2).

Readjustment is necessary after every maintenance operation on the thermostatic compact cartridge (see Adjusting).

II. Non-return valve (F) or (F1), see fold-out page III figs. [15], [16], [18] and [19].

Reassemble in reverse order.

III. Ceramic headpart (P), see fold-out page III figs. [15], [16] and [18].

Reassemble in reverse order.

Observe the correct mounting positions!

Replacement parts, see fold-out page I (* = special accessories).

Care

For directions on the care of this fitting refer to the accompanying Care Instructions.

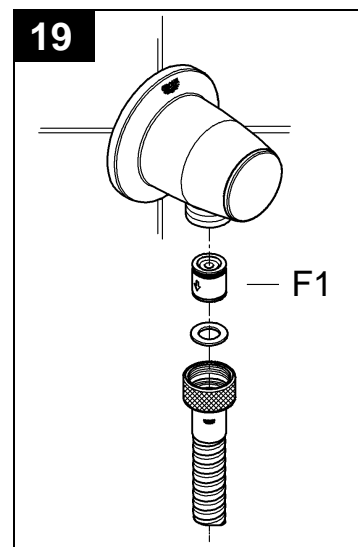
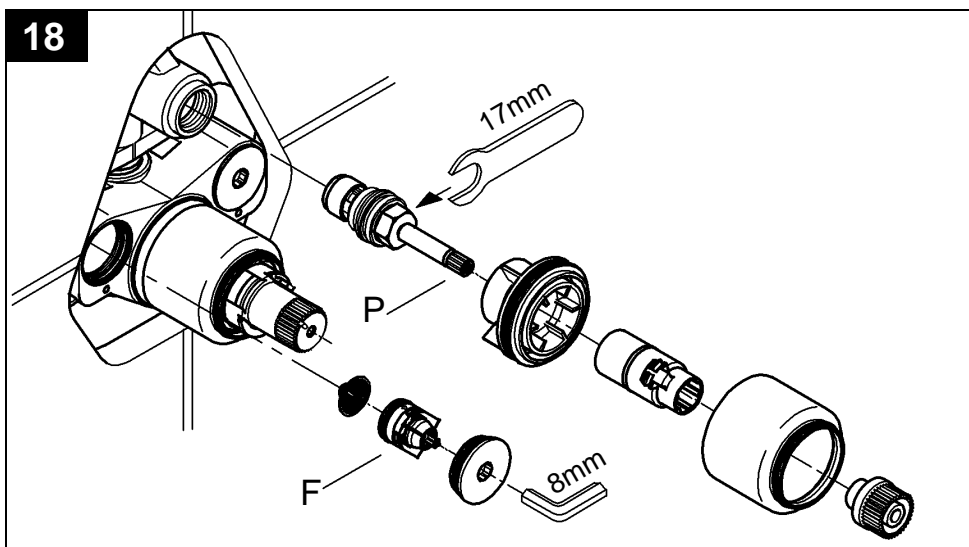
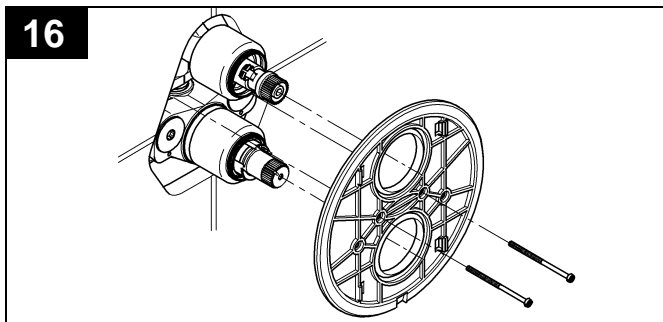
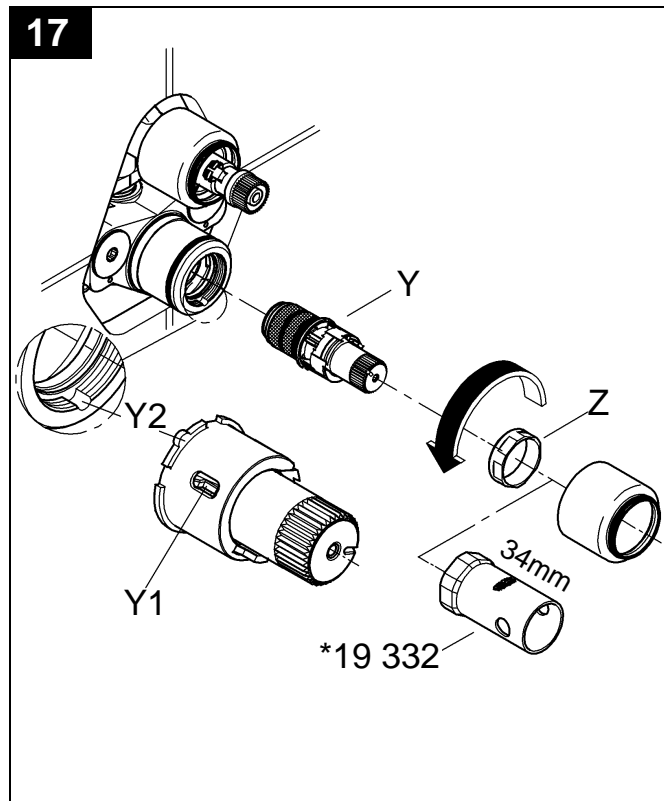
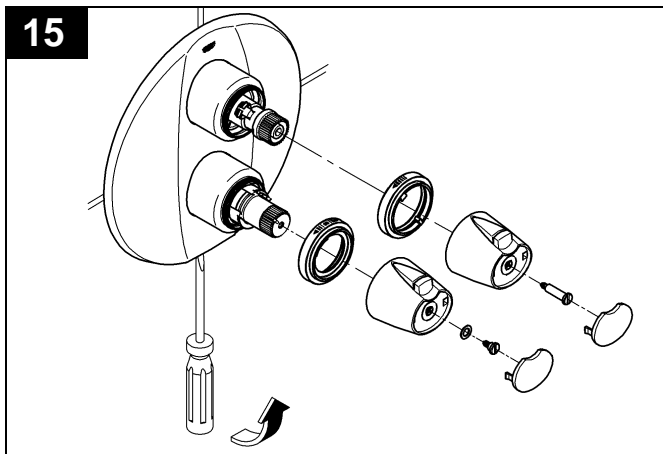
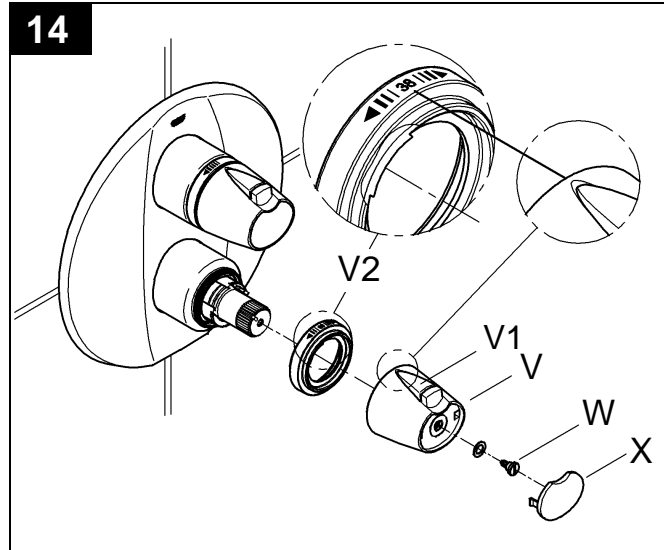
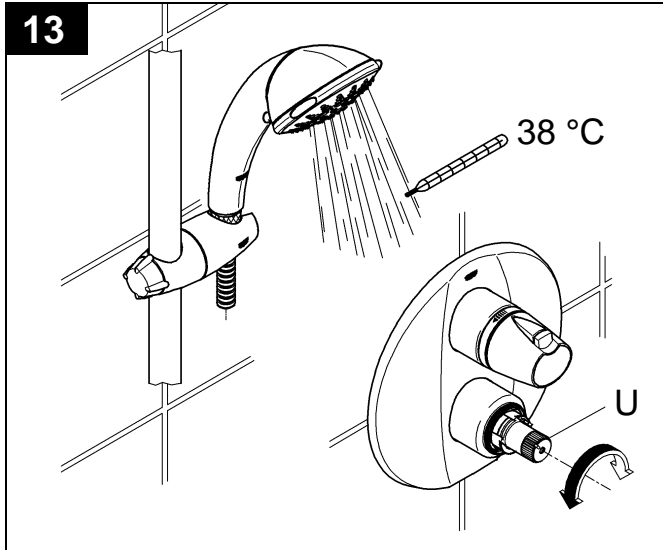



A series of 25 horizontal lines for writing, spaced evenly down the page.

D

Grohe Deutschland
Vertriebs GmbH
Zur Porta 9
32457 Porta Westfalica
Tel.: +49 571 3989-333
Fax: +49 571 3989-999

A

GROHE Ges.m.b.H.
Beichlgasse 6
1100 Wien
Tel.: +43 1 68060-0
Fax: +43 1 6898747

B

GROHE nv - sa
Diependaalweg 4a
3020 Winksele
Tel.: +32 16 230660
Fax: +32 16 239070

BG

Представителство
Grohe AG
в България
Ралф Шпиринг
Клон 11, П.К. 35
8011 Бургас
тел./факс.: +359 56 950104
тел./факс.: +359 56 845549

CDN

GROHE Canada Inc.
1226 Lakeshore Road East
Mississauga, Ontario
Canada, L5E 1E9
Tel.: +1 905 2712929
Fax: +1 905 2719494

CH

Grohe Switzerland SA
Hertistrasse 2
8304 Wallisellen
Tel.: +41 44 8777300
Fax: +41 44 8777320

CN

高仪 (上海)
卫生洁具有限公司
宁桥路615号
201206 上海
中华人民共和国
电话: +86 21 50323535
传真: +86 21 50550363

CY

Nicos Theodorou & Sons Ltd.
12 Dimitsanis Street
CY-1507 Nicosia
P.O. Box 21387
Tel.: +357 22 757671
Fax: +357 22 759085

CZ**SK**

Zastoupení
Grohe AG pro ČR a SR
V Oblouku 104, Čestlice
252 43 Průhonice
Tel.: +420 225 091 081-4
Fax: +420 225 091 085

DK

GROHE A/S
Walgerholm 11
3500 Vaerløse
Tel.: +45 44 656800
Fax: +45 44 650252

E

GROHE España S.A.
C/ Botanica, 78 - 88
Gran Via L'H - Distr. Econòmic
08908 L'Hospitalet de Llobregat
(Barcelona)
Tel.: +34 93 3368850
Fax: +34 93 3368851

EST**LT****LV**

ALPIGRO OÜ
Alar Pihlak
Jõe 5
10151 Tallinn
Tel.: +372 6261204
Fax: +372 6261204

F

GROHE s.à.r.l.
11, Rue des Peupliers
92441 Issy-les-
Moulineaux Cedex
Tel.: +33 1 46625000
Fax: +33 1 46626110

FIN

Oy Teknocalor Ab
Sinikellonkuja 4
01300 Vantaa
Tel.: +358 9 8254600
Fax: +358 9 826151

GB

GROHE Limited
1, River Road
Barking, Essex, IG11 OHD
Tel.: +44 208 5947292
Fax: +44 208 5948898

GR

Nikos Sapountzis S.A.
86, Kapodistriou & Roumelis Str.
142 35 N. Ionia - Athens
Tel.: +30 10 2712908
Fax: +30 10 2715608

H

GROHE Hungary Kft.
Liget u. 1.
2040 Budaörs
Tel.: +36 23 422 468
Fax: +36 23 422 469

HR

ENERTECH GmbH
Division Giersch
Maksimirska 96/II
10000 Zagreb
Tel.: +385 1 2338260
Fax: +385 1 2308024

I

GROHE S.p.A.
Via Castellazzo Nr. 9/B
20040 Cambiago (Milano)
Tel.: +39 2 959401
Fax: +39 2 95940263

IS

BYKO hf.
Skemmuvegi 2
200 Kópavogur
Tel.: +354 515 4000
Fax: +354 515 4099

J

Grohe Japan Ltd.
TRC Building, 3F
1-1 Heiwajima 6-chome, Ota-ku
Tokyo 143-0006
Tel.: +81 3 32989730
Fax: +81 3 37673811

N

GROHE A/S
Karihaugveien 89
1086 Oslo
Tel.: +47 22 906110
Fax: +47 22 906120

NL

GROHE Nederland BV
Metaalstraat 2
2718 SW Zoetermeer
Tel.: +31 79 3680133
Fax: +31 79 3615129

P

GROHE Portugal
Componentes Sanitários, Lda.
Rua Arq. Cassiano Barbosa, 539
1.º Frente Esquerdo
4100-009 Porto
Tel.: +351 22 543 29 80
Fax: +351 22 543 29 99

PL

GROHE Polska Sp. z.o.o.
Ul. Migdalowa 4
02-796 Warszawa
Tel.: +48 22 6451255 - 57
Fax: +48 22 6451258

RUS

Представительство
Grohe AG
Москва, ул. Щипок, 11/28, стр. 1
115054
тел.: +7 095 9374901
факс: +7 095 9374902

RO

S.C. EURO - International S.R.L
B-dul Dinicu Golescu, Nr. 41, Bl.6,
Sc. 3; Ap. 67, Parter
010868 Bucharest (Sector 1)
Tel.: +40 21 3161451
Fax: +40 21 3161452

S

GROHE A/S
Box 2063
194 02 Upplands Väsby
Tel.: +46 771 141314
Fax: +46 771 141315

SLO

GROSAN inženiring d.o.o.
Slandrova 4
1000 Ljubljana
Tel.: +386 1 5633060
Fax: +386 1 5633061

TR

GROME İc ve Dis Ticaret Ltd. Sti.
Bagdat Cad. Ugras Parlar Is
Merkezi No: 305, B Blok D: 12 - 15
34846 Cevizli - Maltepe-Istanbul
Tel.: +90 216 4412370
Fax: +90 216 3706174

UA

Представитель
Grohe AG
в УКРАЇНЕ
Н.И. Топольская
03151 Киев
тел.: +38 44 2751734
факс: +38 44 2499458

USA

GROHE America Inc.
241 Covington Drive
Bloomington
Illinois, 60108
Tel.: +1 630 5827711
Fax: +1 630 5827722

Near and Middle East

Area Sales Office:
GROME Marketing
(Cyprus) Ltd.
11, Lemesou Avenue
Galatariotis Building 1st floor
2112 Aglanjia
P.O. Box 27048
1641 Nicosia
Tel.: +357 22 465200
Fax: +357 22 379188

Far East Area Sales Office:

GROHE Pacific Pte. Ltd.
260 Orchard Road
08-03/04 The Heeren
Singapore 238855
Tel.: +65 6738 5585
Fax: +65 6738 0855

GROHE

ENJOY WATER®