

AFTERCARE INSTRUCTIONS

Your fitting has a high quality finish and should be treated with care to preserve the visible surfaces.

All surface finishes will wear if not cleaned correctly, the only safe way to clean your mixer is to wipe with a soft damp cloth. Stains can be removed using washing up liquid. All bath cleaning powders and liquids will damage the surface of your fitting, even the non-scratch cleaners.

NOTE: Never use abrasive detergents or disinfectants or those containing alcohol, hydrochloric acid or phosphoric acid.

Bristan recommend E-Cloth for cleaning all of our bathroom & kitchen products. Using just water, E-cloth gives a smear free, deep clean by breaking up and holding dirt, which normal cloths leave behind. Order through your Bristan stockist. (ORDER CODE: ECLOTH)

GUARANTEE

All products are manufactured to the highest standards and a 5 year guarantee covers any defect in manufacture.

All products must have access for servicing or replacement during the life of the product.

In the interests of continuous product development we reserve the right to alter specification as necessary

TELEPHONE HELPLINE: 0844 701 6273

Bristan Group Limited
Birch Coppice Business Park
Dordon
Tamworth
Staffordshire
B78 1SG
UK
A Masco Company
Website: www.bristan.com
Telephone: 0844 701 6274
Facsimile: 0844 701 6275



BRISTAN

Tap Repair Kit Metal Heads (R RK MT)

Fitting Instructions & Contents List

Please keep these instructions for future reference and request of replacement part

INSTALLATION

1. Prior to fitting, identify all components and study the diagram before commencing installation.
2. Remove old tap head dependant on type, either by removing an indice and retaining screw.
3. Separate the parts as shown of the page opposite, by removing the cap, then undo the screw underneath. Screw the valve into the tap first, then place the acrylic head onto the spindle. Secure into position with the spindle screw, then replace the cap.
4. If you have queries, please contact the helpline below.



PLEASE NOTE:

In the unlikely event you find a part missing, please contact our Customer Service helpline on **0844 701 6273** for immediate dispatch of part

INSTALLATION DIAGRAM

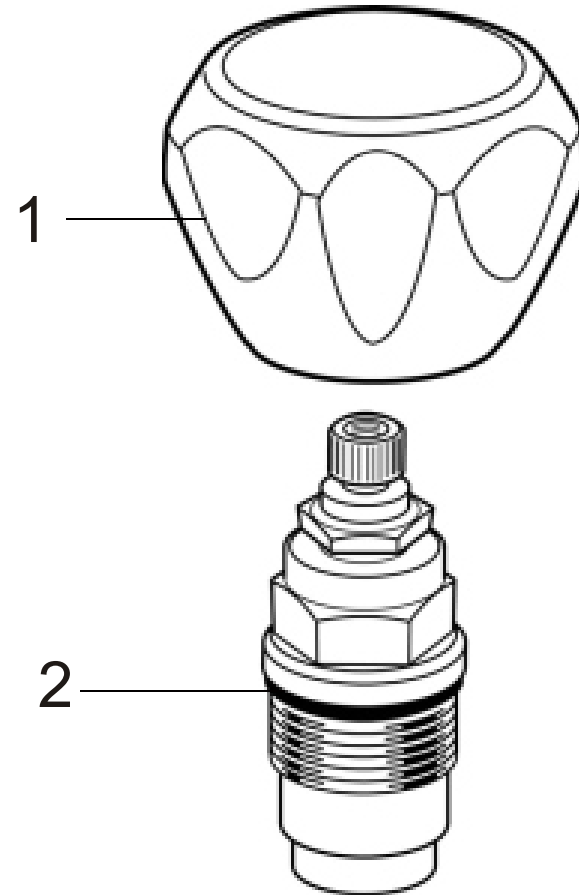

CONTENTS

- | | |
|---------------|------|
| 1. Metal Head | (x2) |
| 2. Valve | (x2) |