

# Installation and operation instruction

## I. Installation Notice.

1. Floor drain should be installed in the location of the tap.
2. Flush pipes to get rid of any debris blocked in pipes before installation.
3. After installation, turn all the joints to make sure they are firmly connected. Then turn water on and off repeatedly to ensure there are no leaks around the joints then the product can be used normally at this stage.

## II. Operation Notice

1. The product is used between water pressure 0.5 to 4bar, water temperature 0-90℃.
2. **The waste and the tap is suitable for being installed in the bathtub which thickness is 5~10 mm(as Figure I).**
3. Regularly clean the tap with soft damp cloth.
4. Read all the instructions completely before proceeding.

## III. Installing steps(Figure II).

1. Screw out the both sides of adapter connector 2.
2. Screw out the lock nut 5, pull 4,3 out in order.
3. Tap body should be plugged in bathtub overflow hole A (Pay attention to use S2.5 wrench adjustment M4 screw length).
4. Put 3,4 into 1 tap in order, then screw in 5 closely by wrench(Pay attention to adjust the direction and the location of the overflow of 1 Tap).
5. Clic-Clac Bath Waste 7 be installed to bathtub .
6. Put 10,9,8 into 6 plastic pipes in order, and put it into 7 at the port of C. At last, use the part 10 plastic nut to lock part 7 bath waste.
7. Screw two adapter connectors 2 in 1 tap body ,and connect to inlet tube 11 (as Figure III,Pay attention to the direction of the cold and heat water inlet).
8. Put two plugs 12 to block up bathtub hole.

● Figure II

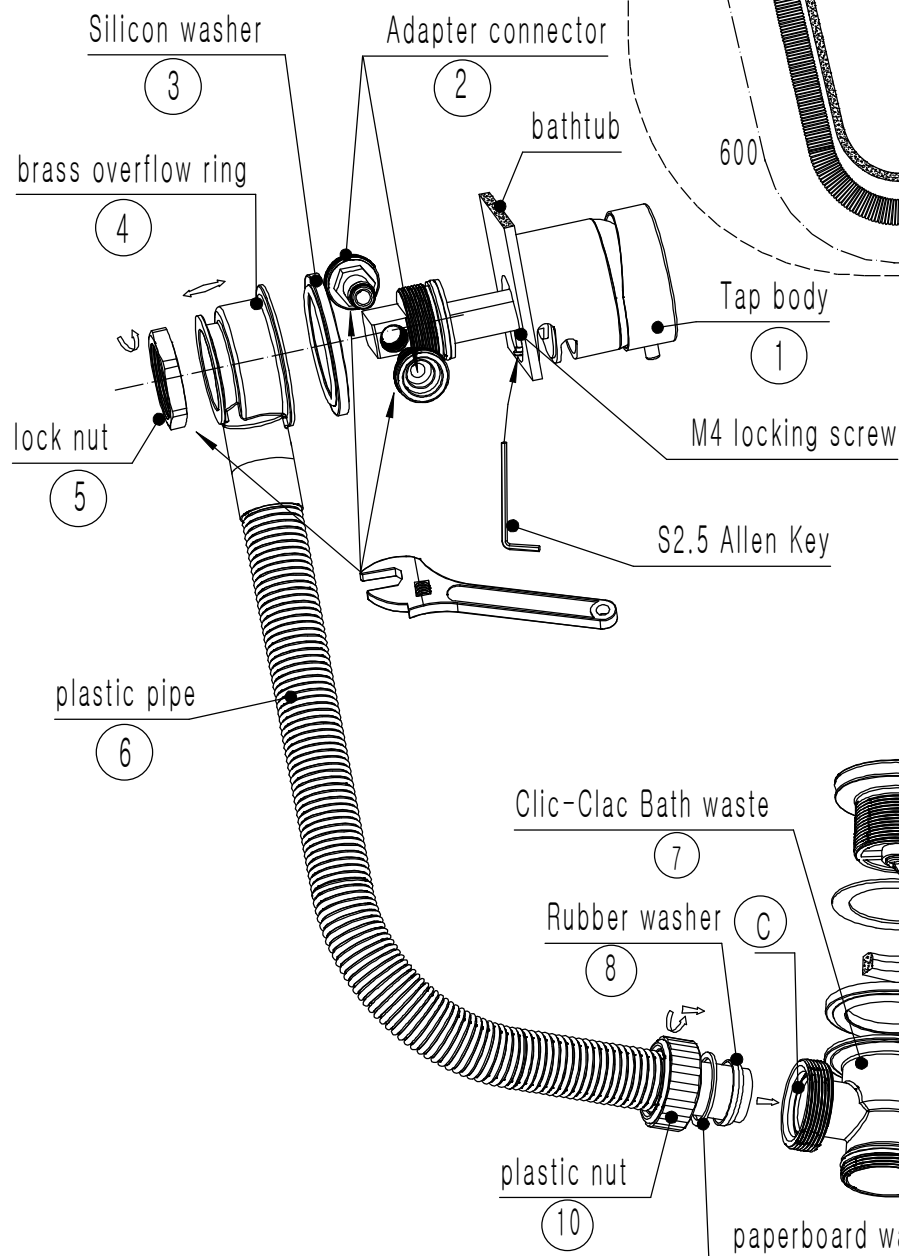

● Figure I

