

URINAL'S

Exposed or Concealed Urinal suitable
for 2 Urinals

RAK
CERAMICS



SPECIFICATION/CODE REFERENCE

Please use the reference codes shown below:

EXPURIPAK2 **CONURIPAK2**

TYPE	Exposed or Conealed Urinal Auto Cistern 9 Litres
FITTINGS	Complete with Sparge Pipe Sets
SPREADERS	Top or Back Inlet Spreader
WASTE	White Plastic Dome Urinal Waste
CISTERN	White Plastic 9 Litres with Auto Syphon
WEIGHT	7.25 kg
COLOURS	Stainless Steel /White
FITTING	Complete with clips, screws and wall plugs
WARRANTY	2 Years

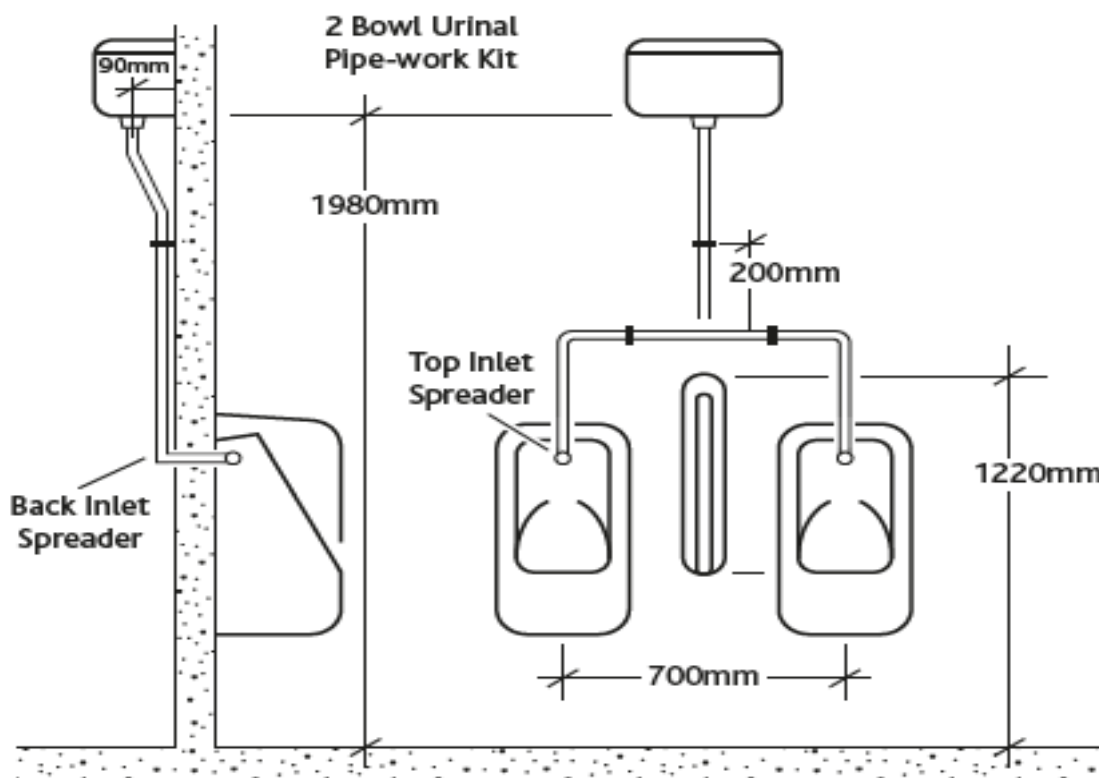

Dimensions: All measurements are in millimeters and are subject to normal manufacturing variations.

Note: Due to a continuing development programme to improve design and performance, the manufacturer reserves all rights to vary specifications without prior informations. Please note accessories are for photographic use only.

Tel: 01730 237850 Fax: 01730 263210. RAK Ceramics, Bradford House, Frenchmans Road, Petersfield, Hampshire GU32 3AW

Contact us at: info.uk@rakceramics.com / Visit us at: www.rakceramics.com 2017